



memmert
Experts in Thermostatics

wiring diagram



humidity chamber

designation: HCP

size: 240

nominal voltage: 115V

drawing number: D39178

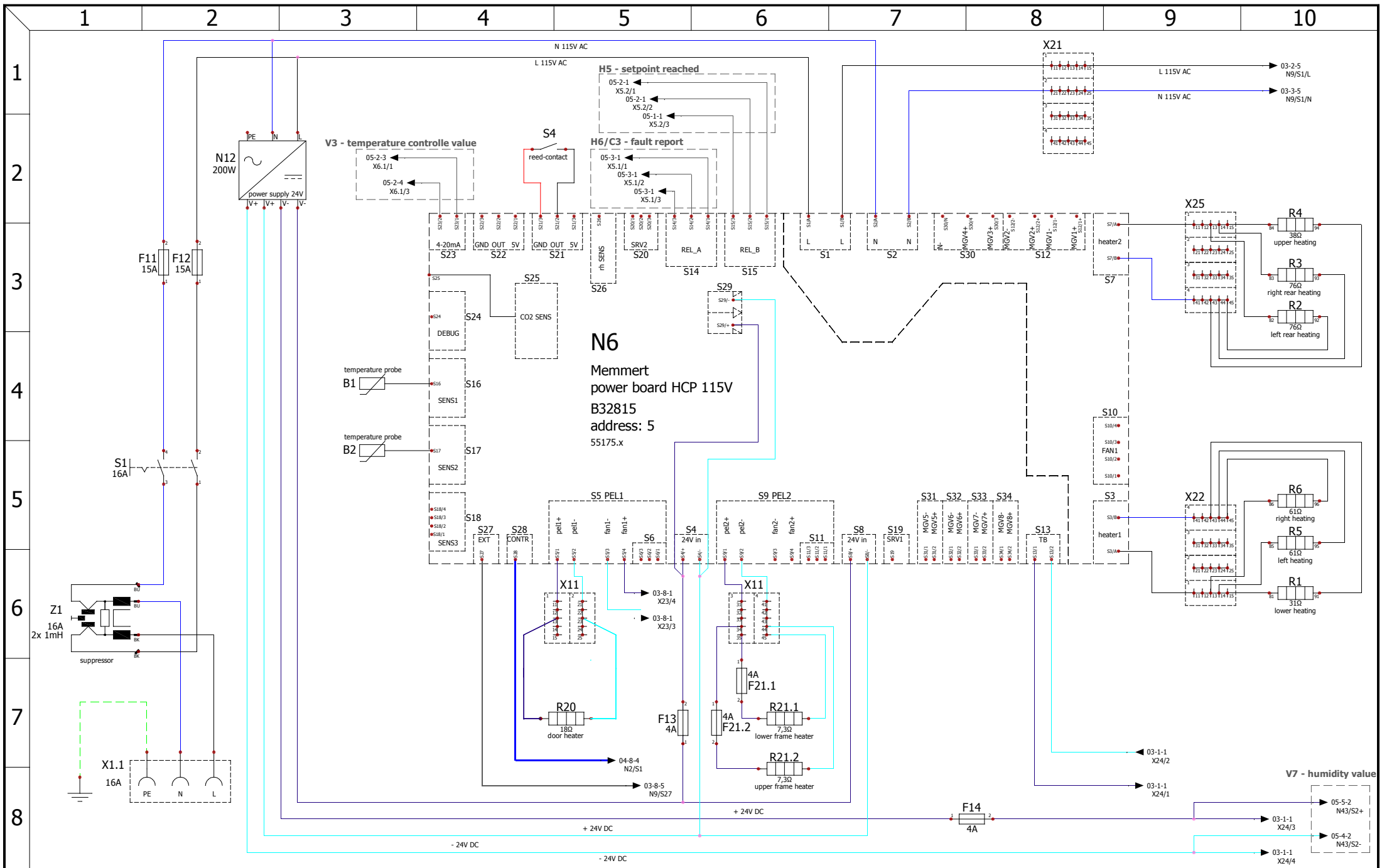

power board			designation:	unit or size:	rev	modification	date	name	page
			HCP	240					02
created by	date	name	drawing number:	nominal voltage:	C	optical improvements	30.11.2018	Chr.Seyfarth	12
checked by	15.01.2018	Chr.Seyfarth	D39178	115V	B	power board replaced	27.06.2018	Chr.Seyfarth	
	11.06.2018	M.Hammerbacher			A	optical improvements	11.06.2018	Chr.Seyfarth	

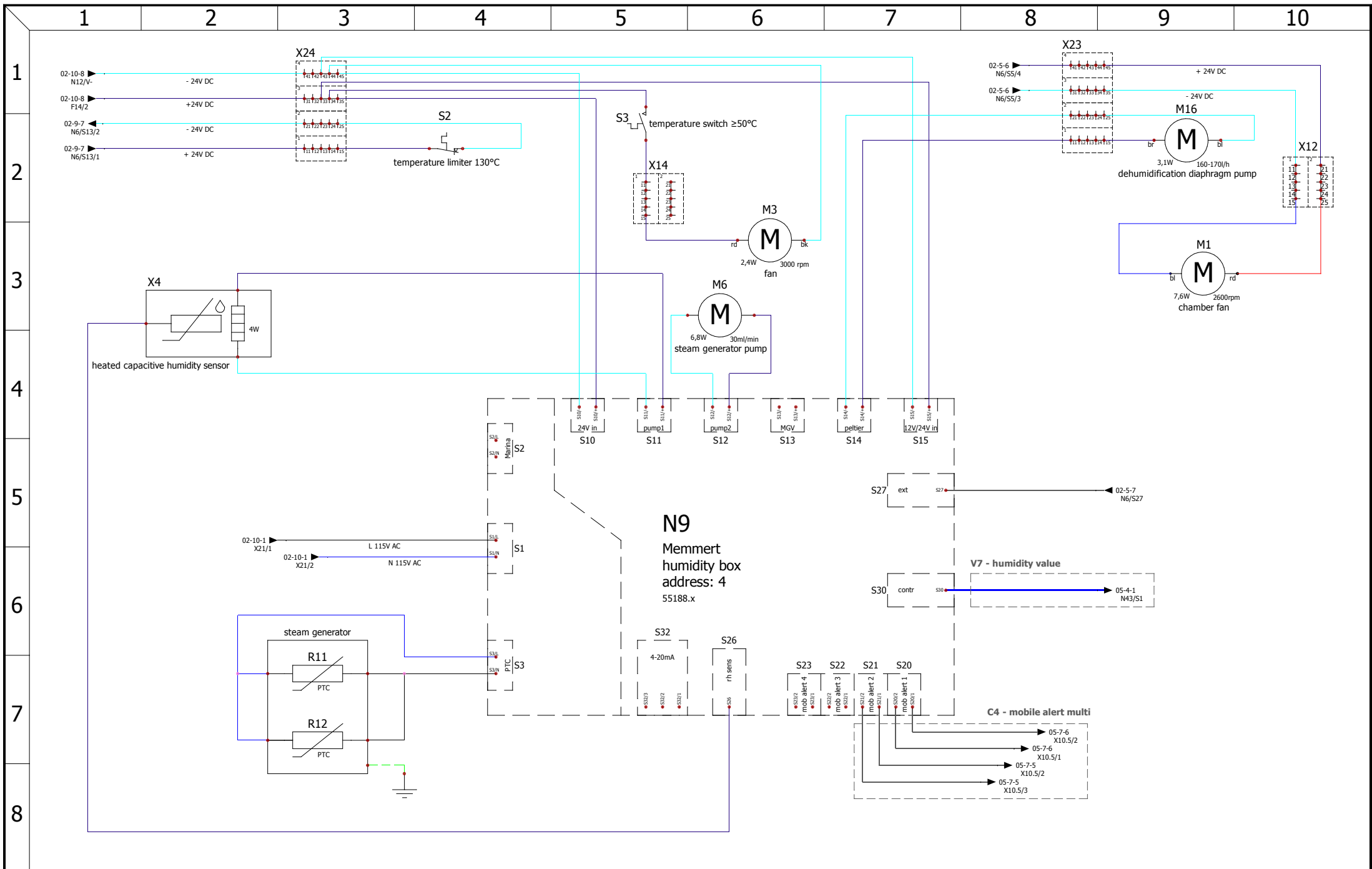

 Experts in Thermostatics	humidity box		designation:	unit or size:	rev	modification	date	name	page	
			HCP	240						03
	created by	date	name	drawing number:	nominal voltage:	C	optical improvements	30.11.2018	Chr.Seyfarth	12
	checked by	15.01.2018	Chr.Seyfarth	D39178	115V	B	power board replaced	27.06.2018	Chr.Seyfarth	
	11.06.2018	M.Hammerbacher			A	optical improvements	11.06.2018	Chr.Seyfarth		

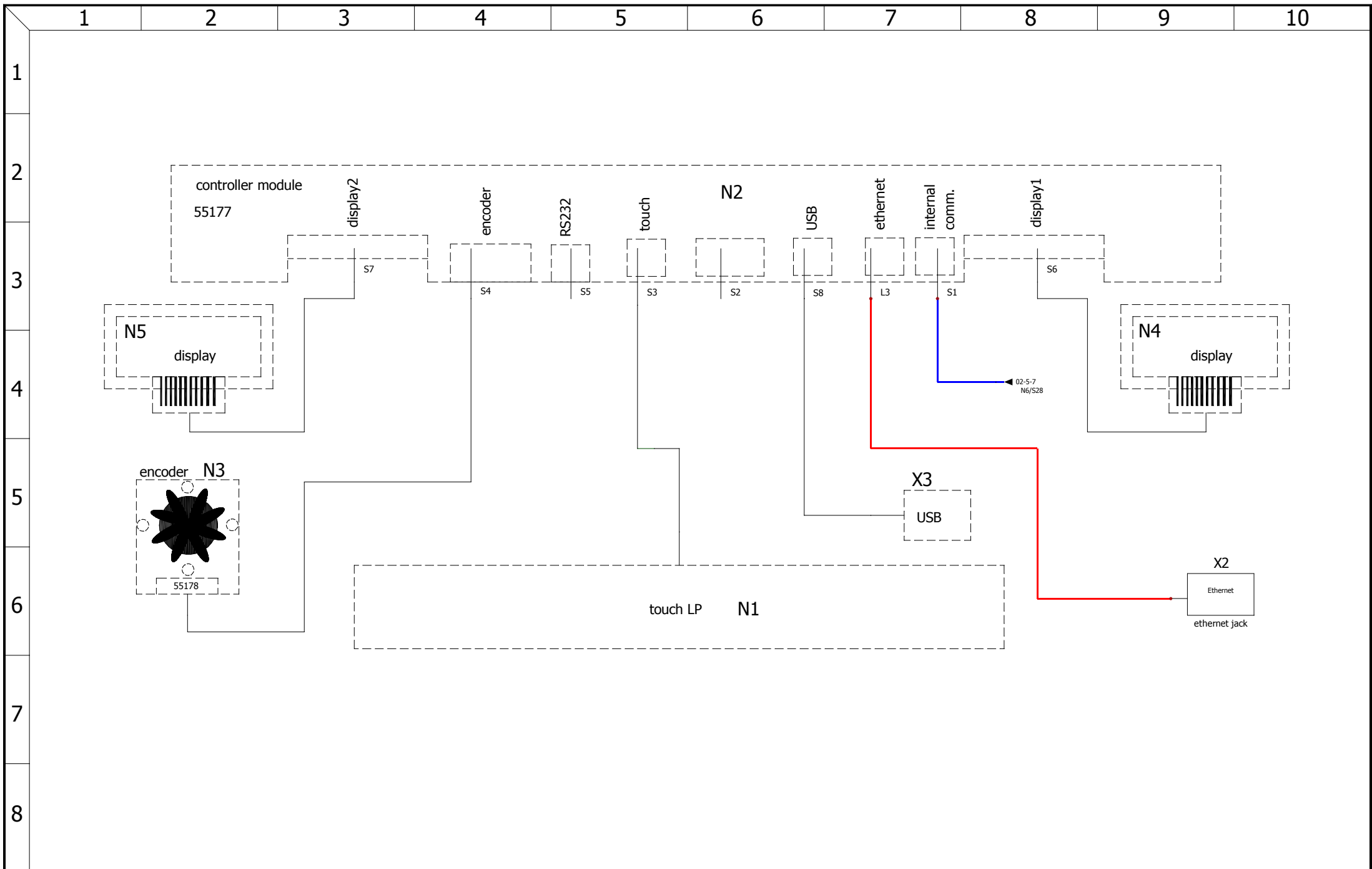

 Experts in Thermostatics	controller unit		designation:	HCP	unit or size:	240	rev	modification	date	name	page
			drawing number:	D39178	nominal voltage:	115V	C	optical improvements	30.11.2018	Chr.Seyfarth	04
	created by	15.01.2018	Chr.Seyfarth	B	power board replaced	27.06.2018	Chr.Seyfarth	12			
	checked by	11.06.2018	M.Hammerbacher	A	optical improvements	11.06.2018	Chr.Seyfarth				

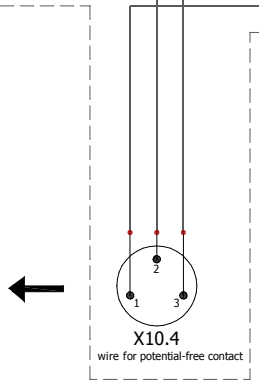
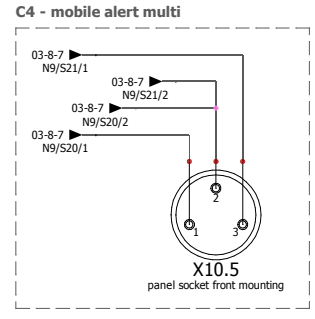
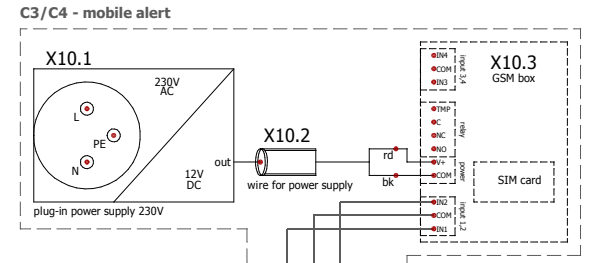
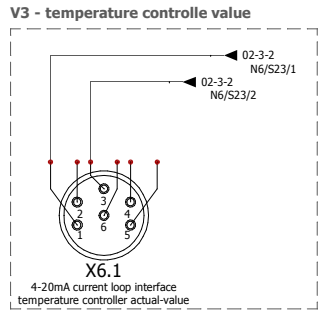
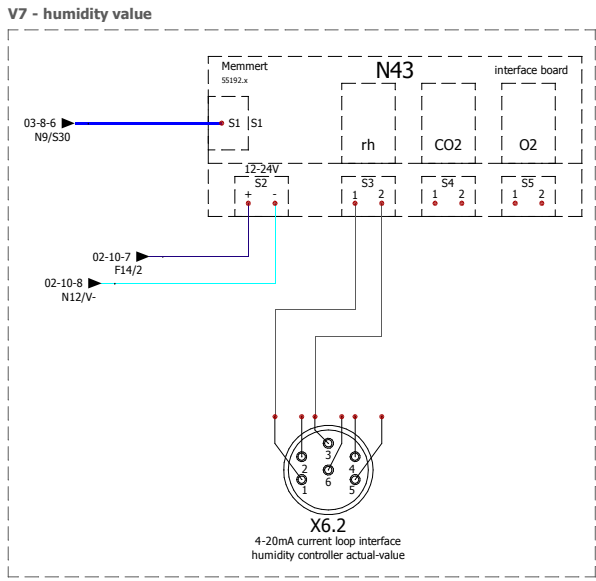
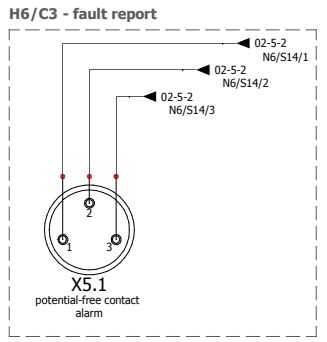
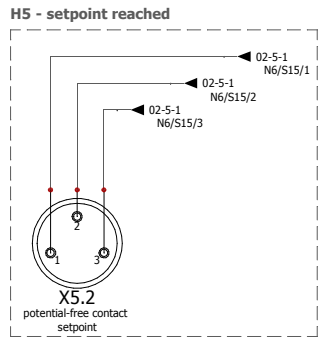

options		
	date	name
created by	15.01.2018	Chr.Seyfarth
checked by	11.06.2018	M.Hammerbacher

designation:	HCP
drawing number:	D39178

unit or size:	240
nominal voltage:	115V

rev	modification	date	name	page
				05
C	optical improvements	30.11.2018	Chr.Seyfarth	12
B	power board replaced	27.06.2018	Chr.Seyfarth	
A	optical improvements	11.06.2018	Chr.Seyfarth	

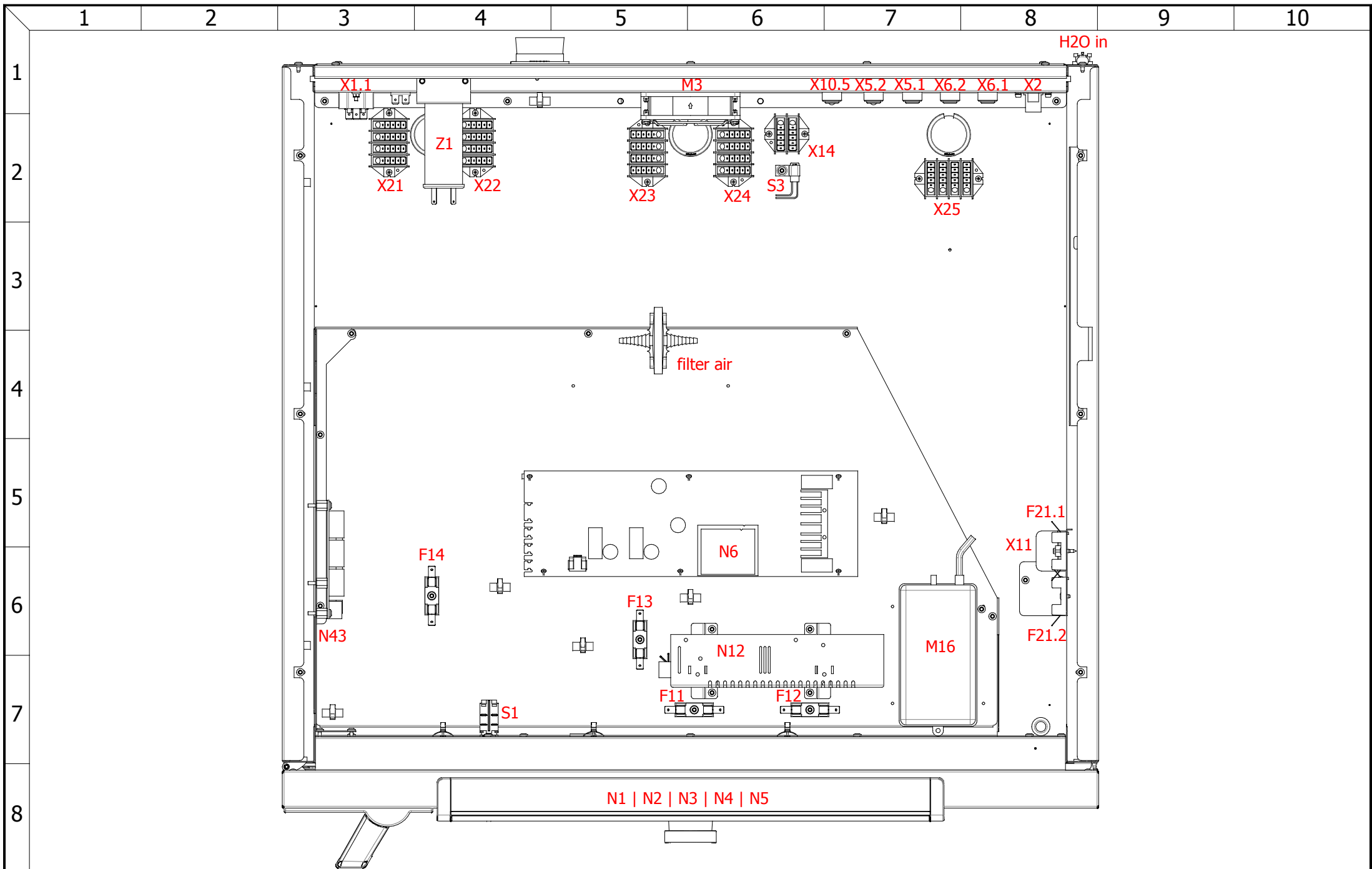

control enclosure		
	date	name
created by	15.01.2018	Chr.Seyfarth
checked by	11.06.2018	M.Hammerbacher

designation:	HCP
drawing number:	D39178

unit or size:	240
nominal voltage:	115V

rev	modification	date	name	page
				06
C	optical improvements	30.11.2018	Chr.Seyfarth	12
B	power board replaced	27.06.2018	Chr.Seyfarth	
A	optical improvements	11.06.2018	Chr.Seyfarth	

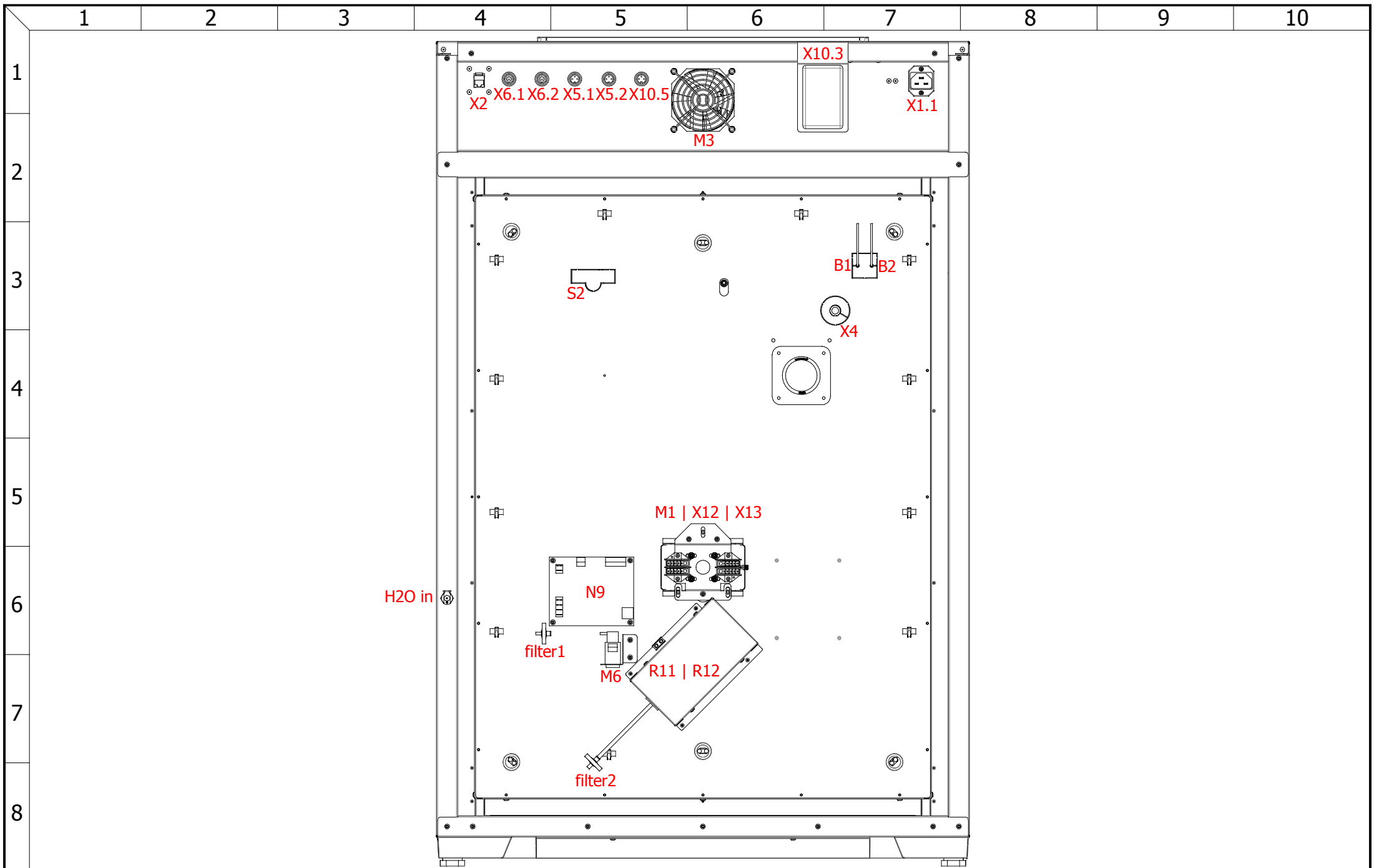



back		
	date	name
created by	15.01.2018	Chr.Seyfarth
checked by	11.06.2018	M.Hammerbacher

designation:	HCP
drawing number:	D39178

unit or size:	240
nominal voltage:	115V

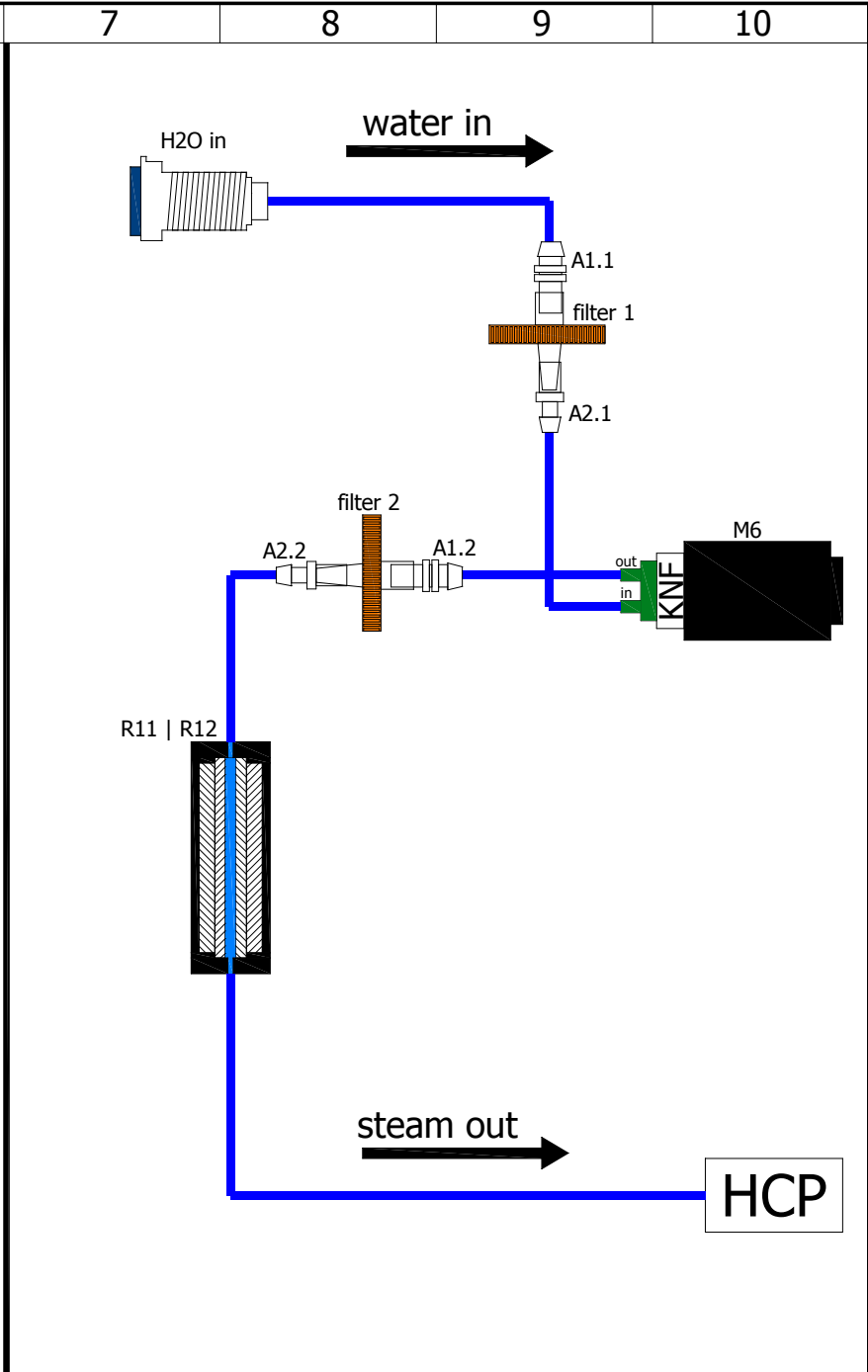
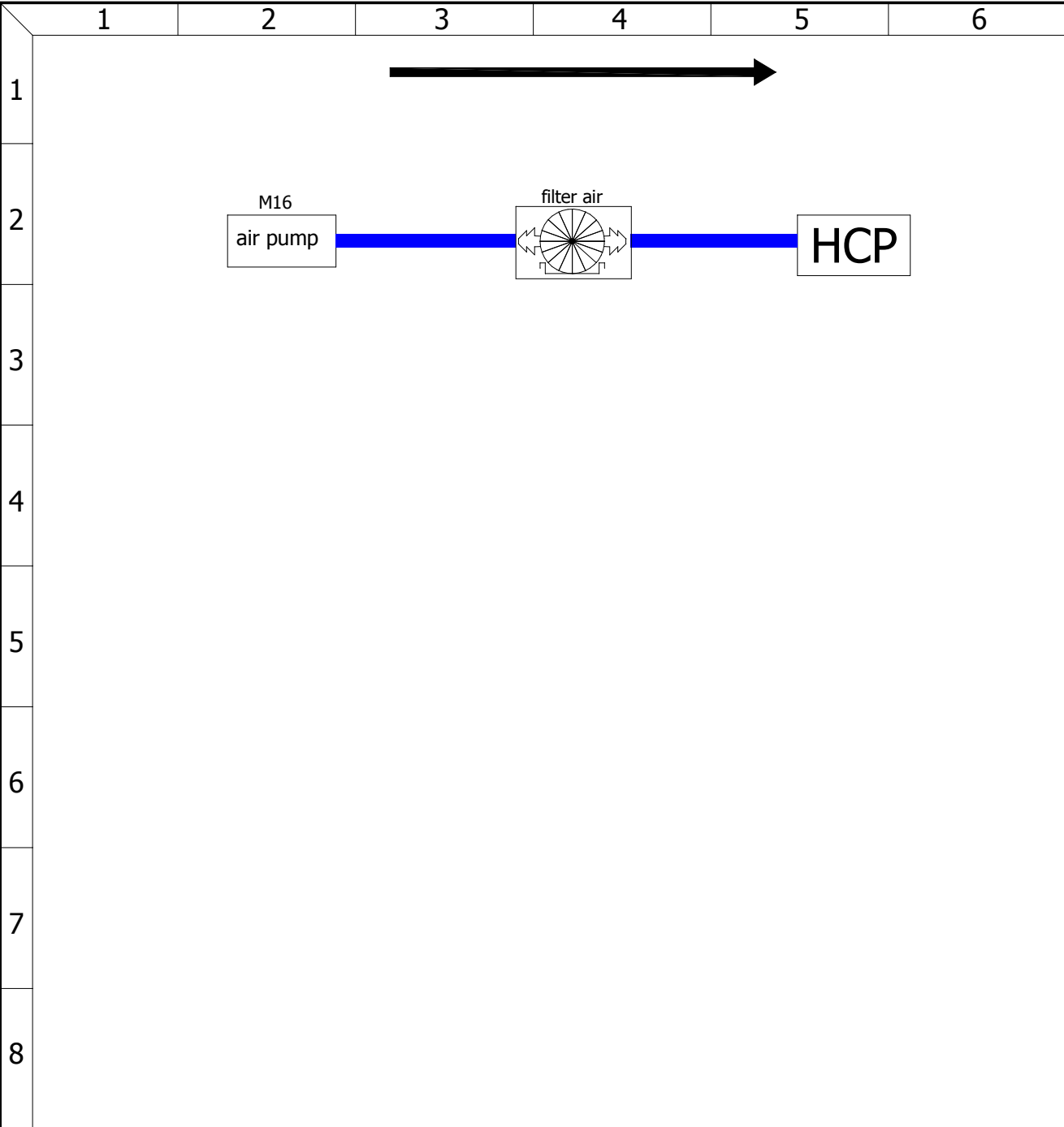
rev	modification	date	name	page
				07
C	optical improvements	30.11.2018	Chr.Seyfarth	12
B	power board replaced	27.06.2018	Chr.Seyfarth	
A	optical improvements	11.06.2018	Chr.Seyfarth	



 Experts in Thermostatics	air/water connections		designation:	HCP	unit or size:	240	rev	modification	date	name	page
			drawing number:	D39178	nominal voltage:	115V	C	optical improvements	30.11.2018	Chr.Seyfarth	08 12
	created by	15.01.2018	Chr.Seyfarth			B	power board replaced	27.06.2018	Chr.Seyfarth		
	checked by	11.06.2018	M.Hammerbacher			A	optical improvements	11.06.2018	Chr.Seyfarth		

mark	article number	description	quantity
-	B39184	cable harness HCP 240	1
B1 B2	E07499	temperature sensors	2
F11 F12	E02387	fuse 15A	2
F13 F14 F21.1 F21.2	E07327	fuse 4A	4
M1 X12 X13	B38840	fan motor preassembled ICO 50/105/150/240	1
M3	E04796	DC brushless fan	1
M6	E07290	solenoid diaphragm pump	1
M16	E07336	air pump	1
N1 N2 N3 N4 N5	B30890	controller unit small plus twin display	1
N6	B32815	power board HCP 115V	1
N9	B38929	humidity power board	1
N12	B38079	switching power supply 24V/200W	1
R1	B33442	lower heating ICO/HCP 240	1
R2	B33443	left rear heating ICO/HCP 240	1
R3	B33444	right rear heating ICO/HCP 240	1
R4	B33445	upper heating ICO/HCP 240	1
R5	B33446	left heating ICO/HCP 240	1
R6	B33447	right heating ICO/HCP 240	1
R11 R12	B35344	steam generator ICO 50/105/150/240	1
R20	B40281	door heater ICO/HCP 240	1
R21.1	B39289	lower frame heater HCP 240	1
R21.2	B39290	upper frame heater HCP 240	1

mark	article number	description	quantity
S1	E06137	power push-button-switch	1
S2	E06869	temperature limiter 130°C	1
S3	E07292	temperature switch ≥50°C	1
S4	B38952	reed-contact	1
X2	E06251	ethernet jack	1
X4	B39291	heated capacitive humidity sensor	1
X11	E01838	distribution block 4pol.	1
X14	E00098	distribution block 2pol.	1
X21 X22 X23 X24 X25	E01838	distribution block 4pol.	5
X1.1	E06135	connector plug	1
Z1	E07420	interference suppression filter	1

bill of materials (standard)			designation:	unit or size:	rev	modification	date	name	page									
			HCP	240					10									
<table border="1"> <tr> <td></td> <td>date</td> <td>name</td> </tr> <tr> <td>created by</td> <td>15.01.2018</td> <td>Chr.Seyfarth</td> </tr> <tr> <td>checked by</td> <td>11.06.2018</td> <td>M.Hammerbacher</td> </tr> </table>				date	name	created by	15.01.2018	Chr.Seyfarth	checked by	11.06.2018	M.Hammerbacher	drawing number:	nominal voltage:	C	optical improvements	30.11.2018	Chr.Seyfarth	12
				date	name													
			created by	15.01.2018	Chr.Seyfarth													
checked by	11.06.2018	M.Hammerbacher																
D39178	115V	B	power board replaced	27.06.2018	Chr.Seyfarth													
		A	optical improvements	11.06.2018	Chr.Seyfarth													

mark	article number	description	quantity
N43	B39321	interface board	1
X5.1 X5.2	B32965	potential-free contact H5,H6,H7,C3	2
X6.1 X6.2	B31202	panel socket for 4-20mA current interface	2
X10.1	E06631	plug-in power supply 230V	1
X10.2	E06763	low-voltage connection cable with socket	1
X10.3	E06429	GSM Box	1
X10.4	E03148	circular connectors with threaded joint	1
X10.5	B39367	potential-free contact C4	1

bill of materials (options)

	date	name
created by	15.01.2018	Chr.Seyfarth
checked by	11.06.2018	M.Hammerbacher

designation:
HCP

drawing number:
D39178

unit or size:
240

nominal voltage:
115V

rev	modification	date	name	page
				11
C	optical improvements	30.11.2018	Chr.Seyfarth	12
B	power board replaced	27.06.2018	Chr.Seyfarth	
A	optical improvements	11.06.2018	Chr.Seyfarth	

mark	article number	description	quantity
A1.1	E07322	adapter male	1
A1.2	E07323	adapter female	1
A2.1	E07322	adapter male	1
A2.2	E07323	adapter female	1
filter 1 filter 2	E07324	filter H2O	2
filter air	E03401	filter O2/CO2/N2	1
H2O in	E07050	water connection socket	1

bill of materials (gas/water)	designation:		HCP	unit or size:	240	rev	modification	date	name	page
	drawing number:		D39178	nominal voltage:	115V	C	optical improvements	30.11.2018	Chr.Seyfarth	12
	created by	15.01.2018	Chr.Seyfarth			B	power board replaced	27.06.2018	Chr.Seyfarth	12
checked by	11.06.2018	M.Hammerbacher			A	optical improvements	11.06.2018	Chr.Seyfarth		